

- **LIGHTWEIGHT**
- **VERY**
- **RAPID**
- **ERECT**

LVRE



MOBILE FORWARD AIRCRAFT SHELTER

LVRE is a lightweight, Very Rapidly Erected and readily transportable, mobile field shelter. It is a truly integrated system specifically designed for the upkeep of aircraft on forward deployment for extended periods. Its primary use is in mission preparation, pre and post flight inspection, to carry out minor rectification and to protect sophisticated aircraft systems from the full range of harsh environments.

The LVRE (A) provides shelter for the Apache attack helicopter. Transportable in a C120/C130 aircraft, the design is adaptable to accommodate a range of other airframes. It is both fast and easy to construct and may be erected over an immobile aircraft by a team of four men working at ground level and without need for heavy mechanical aid, power supply and complex instructions. Once erected, LVRE may be mobilised to withdraw from the aircraft, if necessary. Its main features are:

- Time to unpack and erect: team of 4, 6 hours
- Encloses flight-configured aircraft
- Time to repack and move on: team of 4, 4 hours
- Max structural component 2-man portable, max fabric 4-man portable
- Can be erected over an immobile aircraft
- Simple entry and exit procedure enables aircraft launch in adverse weather
- Shelter deployable under windy conditions
- No cranes or handling machinery required for assembly
- Working at height not necessary



The LVRE utilises lightweight aluminium and composite materials with a tensile fabric cover providing inherent durability under extreme conditions. It provides IRR (Infra Red Reflective) signature, total blackout and withstands the harsh environmental conditions to which it is exposed in the field, where it has proven performance.



structured solutions by

ABLY
SHELTERS

www.tacticalshelters.com

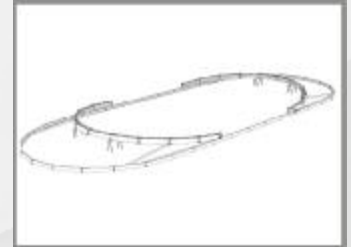
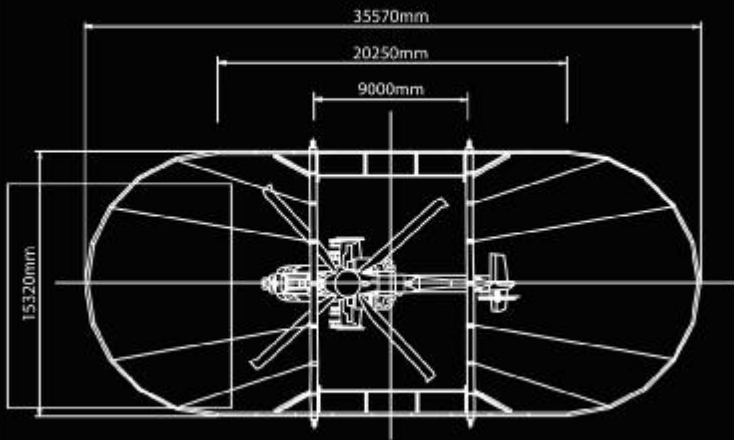

Lay Ground Beam



Raise Arches



Tension Fabric



Complete in 6 hours



Flight-Configured Aircraft

TECHNICAL INNOVATION

Abyl Shelters specialises in the provision of innovative solutions for re-deployable shelters. Our staff of multidisciplinary engineers and designers work closely with clients to create structures that meet all aspects of demanding operational requirements. The LVRE demonstrates the success of this approach in providing simultaneously a large but very light-weight, highly mobile structure - mobilised or demobilised in only 4 or 6 hours.

Innovation 1

Ground beam design means:

- Minimal ground preparation time
- No anchors required during deployment (winds <18 knots)
- Deployable on uneven ground
- Shelter load is distributed, reducing ground damage
- Can be moved on wheels on hard surfaces
- Fabric securely fastened, regardless of terrain
- Ballast can be used where anchors are not permitted
- Can be sealed against tarmac or concrete for long term deployment

Innovation 2

Composite structural design provides for:

- Lightweight components, all assembled at ground level
- Spigot free, high speed arch construction
- No water seepage through keder grooves
- Components sized to fit onto standard aircraft pallets

Innovation 3

- Innovation award - "Highly Commended" for the use of tensile fabrics
- Fabric selected for IR reflectance, blackout camouflage over-paint
- Characteristics, fire retardance, biochemical resistance, UV tolerance durability
- Weight 6.8 tonnes
- Height 7.8 metres
- Packs into 1 x 40' ISO container or 2 x 20' ISO containers
- Rotor downwash tolerance: 15m
- Blackout integrity with personnel doors in use
- Integrated power distribution, lighting and ventilation
- NATO climate specification A1, A2, A3, B3, C0, C1, C2
- Wind speeds up to 57 knots (75 knot gusts)
- Snow/ice loading 0.5 kN/m²
- UK MoD type approval

